



BC FIBER
connect The Future
B&C GROUP

Pigtail
SC / LC / FC / ST

OM2 Multimode
50/125 μm

LSZH
Low Smoke Zero Halogen

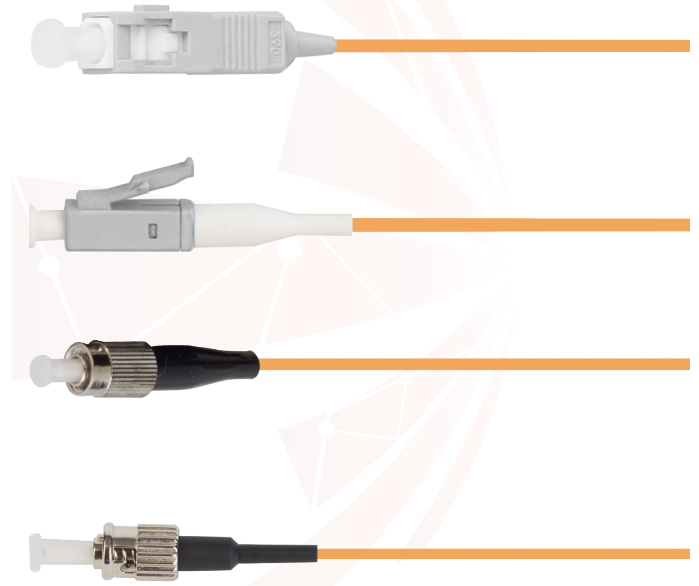

Cable Mechanical Properties

Connector LC / SC / FC / ST	Multimode
Polishing	UPC
Return loss	≥ 65 dB
Insertion loss	< 0.25 dB (IEC Grade B)
Length	1.5 m / 2.0 m
Sheath material	LSZH, UL-94 V0
Ferrule material	Ceramic (zirconia)
Ferrule diameter	1,25mm / 2,5 mm
Temperature range	-20°C +70°C
Outer diameter	900 \pm 5 μm
Bending radius (static)	10 x 0,9 mm
Attenuation @ 850 / 1300 nm (dB/km)	-
Attenuation @ 1310 / 1383 / 1550 nm (dB/km)	$\leq 0,4 / \leq 0,4 / \leq 0,4$

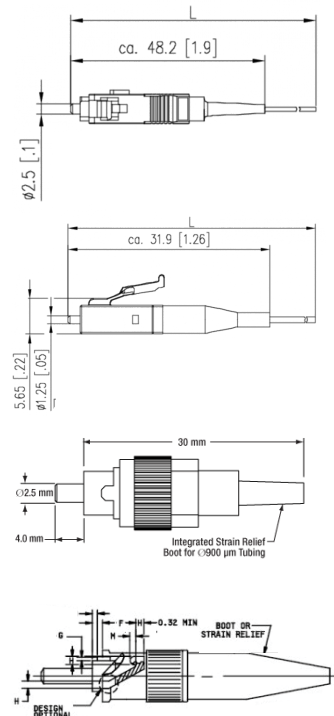

B&C Fiber Group duplex patch leads are manufactured in our own modern facilities from the highest quality optical fiber, terminated with ceramic ferrule connectors of various types. Cable preparation, termination and performance testing is carried out to strictly managed procedures, with high focus on quality control. **All B&C Fiber optical products are 100% optical tested and come with a test certificate.** Our products are conform with all industry typical standards: **IEC, EIA, TIA or Telcordia**